

# 01005 MLCC Ultra Miniature Capacitors

## General Specifications

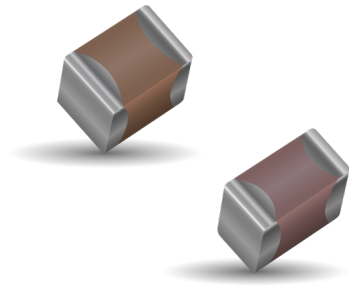

### GENERAL DESCRIPTION

Offered in a complete range of products for both general and specialized applications and designed to meet a wide variety of needs. We have a worldwide network in order to supply our global customer bases quickly and efficiently. All of our products are highly reliable due to their monolithic structure of high-purity and superfine uniform ceramics and their integral internal electrodes.

Using Kyocera's latest manufacturing technology and materials with high dielectric constants, we produce extremely compact components with exceptional specifications. Our stringent quality control in every phase of production from material procurement to shipping ensures consistent manufacturing and superior quality.

### HOW TO ORDER

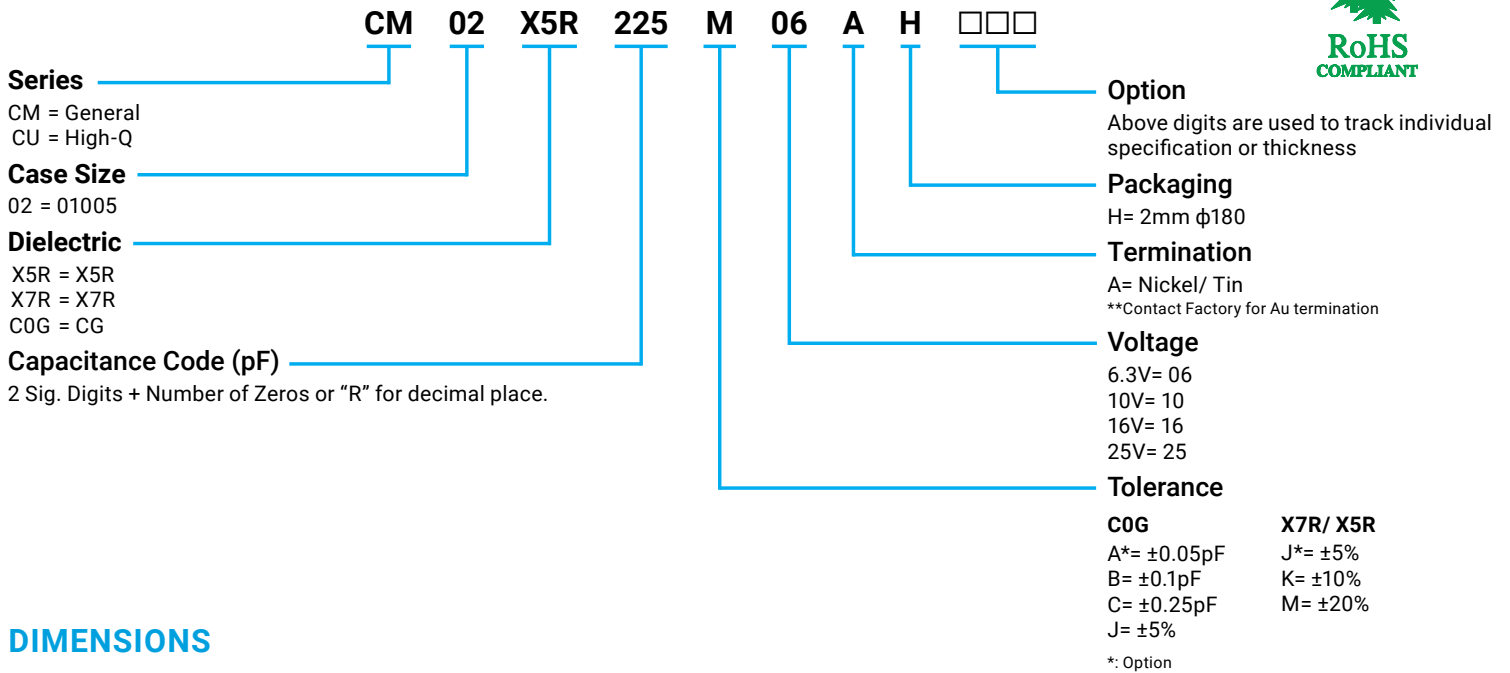

### DIMENSIONS

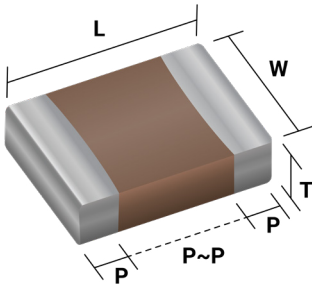

### PACKAGING CODE

20kp	P		8		2	
100Pcs	Taping Material		Taping Width		Pitch	
	Code	Material	Code	Width	Code	Width
	P	Paper	8	8 mm	2	2 mm

Size	Code		Dimension Code	Dimension (mm)						Quantity per reel
	EIA	JIS		L	W	T	P min.	P max.	P to P min.	
02	01005	0402	A	0.4 $\pm$ 0.02	0.2 $\pm$ 0.02	0.2 $\pm$ 0.02	0.07	0.14	0.13	20kp(P8/2)

# 01005 MLCC Ultra Miniature Capacitors

## General Specifications

### COG / NP0 DIELECTRIC

Size (EIA Code)		CM02 (01005)					
Rated Voltage (Vdc)		16			25		
Tolerance		B	C	J	B	C	J
Capacitance (pF)		±0.1pF	±0.25pF	±5%	±0.1pF	±0.25pF	±5%
R20	0.2						
R50	0.5					A	
1R0	1.0						
1R5	1.5	A			A		
2R0	2.0						
3R0	3.0		A				
4R0	4.0					A	
5R0	5.0						
6R0	6.0						
7R0	7.0						
8R0	8.0						
9R0	9.0						
100	10						A
120	12						
150	15			A			
180	18						A
220	22						
270	27						
330	33						
390	39						
470	47			A			
560	56						
680	68						
820	82						
101	100						
121	120						
151	150						
181	180						
221	220			A			

< Standard Capacitor Value: E12 Series >

\*Please Contact for capacitance values other than standard

CU Series
  CM Series
  CM & CU Series

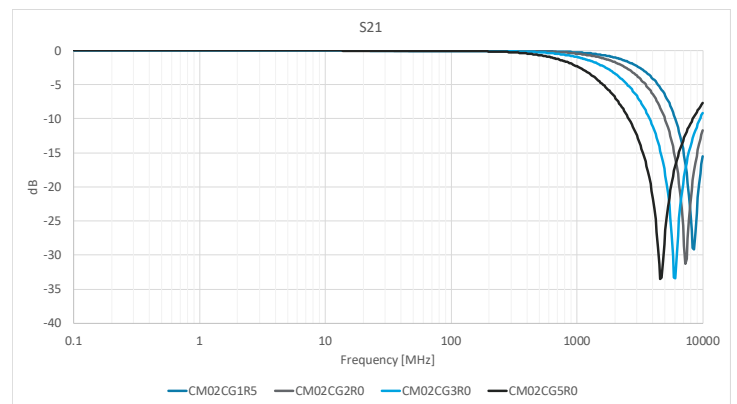
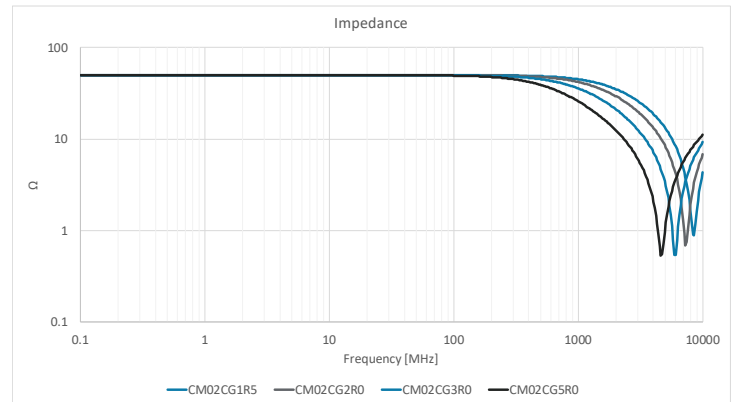

### COG / NP0 CAP CHART: Alphabets denotes dimensions.

Please refer to the below table for details.

Size	Dimension Code	Dimension (mm)			Packaging				
		L	W	T	φ 180 Reel				
					Code	Quantity	Taping Material	Taping Width	Cavity Pitch
02	A	0.4±0.02	0.2±0.02	0.2±0.02	H	20,000	Paper	8mm	2mm

# 01005 MLCC Ultra Miniature Capacitors

## General Specifications

### X5R DIELECTRIC

Size (EIA Code)		CM02 (01005)				
Rated Voltage (Vdc)		6.3		10	16	
Tolerance		K	M	M	K	M
Capacitance		±10%	±20%	±20%	±10%	±20%
101	100 pF				A8	A8
151	150 pF					
221	220 pF					
331	330 pF					
471	470 pF					
681	680 pF					
102	1000 pF					
152	1500 pF					
222	2200 pF					
472	4700 pF					
682	6800 pF					
103	10000 pF					
153	15000 pF	A8	A8			
223	22000 pF					
333	33000 pF					
473	47000 pF					
104	0.10 μF			A8		
224	0.22 μF	A8	A8			
474	0.47 μF		A8			
105	1.0 μF					
225	2.2 μF					
475	4.7 μF					
106	10 μF					
156	15 μF					
226	22 μF					

< Standard Capacitor Value>  
Cap Value < 0.1 μF: E6 Series  
Cap value ≥ 0.1 μF: E3 Series

 CM Standard Spec. 1

 CM Standard Spec. 2

X5R Tan δ Code	Tan δ
3	5.0% max.
4	7.0% max.
5	7.5% max.
7	10.0% max.
8	12.5% max.
9	15.0% max.
10	20.0% max.

### X7R DIELECTRIC

Size (EIA Code)		CM02 (01005)
Rated Voltage (Vdc)		16
Capacitance		
101	100 pF	
151	150 pF	
221	220 pF	
331	330 pF	
471	470 pF	
681	680 pF	
102	1000 pF	
152	1500 pF	
222	2200 pF	A8

< Standard Capacitor Value>  
Cap Value < 0.1 μF: E6 Series

 CM Standard Spec. 1

X7R Tan δ Code	Tan δ
2	3.5% max.
3	5.0% max.
5	7.5% max.
8	12.5% max.

### X7R/ X5R CAP CHART: Two digit denotes dimensions and tan δ code

Please refer to the below table for detail.

Size	Dimension Code	Dimension (mm)			Packaging				
		L	W	T	φ 180 Reel				
					Code	Quantity	Taping Material	Taping Width	Cavity Pitch
02	A	0.4±0.02	0.2±0.02	0.2±0.02	H	20,000	Paper	8mm	2mm

# 01005 MLCC Ultra Miniature Capacitors

## CM/CU (Standard Spec. 1) Specifications and Test Methods



Test Items		Test Conditions			Specifications									
Capacitance Value (C)		Capacitance	Frequency	Volt	Within Tolerance									
Q		C <sub>≥</sub> 1000pF	1 MHz ±10%	0.5 to 5 Vrms	"C <sub>≥</sub> 30pF : Q <sub>≥</sub> 1000 C<30pF : Q <sub>≥</sub> 400+20C"									
		C <sub>≤</sub> 1000pF	1 kHz ±10%											
Insulation Resistance (IR)		Apply the rated voltage for 1 minute, and measure it in normal temperature and humidity. The charge and discharge current of the capacitor must not exceed 50mA.			Over 10000MΩ or 500MΩnμF, whichever is less.									
Dielectric Resistance		Apply *3 times the rated voltage for 1 to 5 seconds twice. The charge and discharge current of the capacitor must not exceed 50mA. *CU02CΔR20-120/25V: twice			No defect									
Appearance		Microscope			No defect									
Termination Strength		Apply a sideward force of 100g (1N) to PCB-mounted sample.			No defect									
Bending Strength		Glass epoxy PCB: Fulcrum spacing: 90mm, duration time 10 Seconds.			No Significant damage with 1mm bending.									
Vibration Test	Appearance	"Vibration Frequency: 10-55 (Hz) Amplitude: 1.5mm Sweeping Condition: 10 → 55 → 10 Hz/ 1 minute in X, Y and Z Directions: 2 hours each, 6 hours total"			No defect									
	Δ C				Within Tolerance									
	Q				"C <sub>≥</sub> 30pF : Q <sub>≥</sub> 1000 C<30pF : Q <sub>≥</sub> 400+20C"									
Soldering Heat Resistant	Appearance	"Soak the Sample in 260°C ± 5°C solder for 10±0.5 seconds and place in normal temperature and humidity. Measure the sample after 24± 2 hours. (Pre-heating conditions)			No defect									
	Δ C				Within ± 2.5% or ± 0.25 pF, whichever is larger									
	Q	<table border="1"> <thead> <tr> <th>Order</th> <th>Temperature</th> <th>Time</th> </tr> </thead> <tbody> <tr> <td>1</td> <td>80-100°C</td> <td>2 min</td> </tr> <tr> <td>2</td> <td>150-200°C</td> <td>2 min</td> </tr> </tbody> </table>			Order	Temperature	Time	1	80-100°C	2 min	2	150-200°C	2 min	"C <sub>≥</sub> 30pF : Q <sub>≥</sub> 1000 C<30pF : Q <sub>≥</sub> 400+20C"
	Order	Temperature	Time											
	1	80-100°C	2 min											
2	150-200°C	2 min												
IR				Over 10000MΩ or 500MΩnμF, whichever is less.										
Withstanding Voltage	The charge and discharge current of the capacitor must not exceed 50mA for IR and Withstanding Voltage measurement."			Resist without problem										
Solderability		Soak Condition:			Solder Coverage : 95% min.									
		Sn-3AG-0.5Cu	245 ±5°C	3 ±0.5 sec.										
		Sn63 Solder	235 ±5°C	2 ±0.5 sec.										
Temperature Cycle	Appearance	(Cycle)			No defect									
	Δ C	Room Temperature (3min.) → Lowest Operating Temperature (30 min.) → Room Temperature (3 min.) → Highest Operating Temperature (30 min.)			Within ± 2.5% or ± 0.25 pF, whichever is larger									
	Q				"C <sub>≥</sub> 30pF : Q <sub>≥</sub> 1000 C<30pF : Q <sub>≥</sub> 400+20C"									
	IR	After 5 cycles, measure after 24 ± 2 hours.			Over 10000MΩ or 500MΩnμF, whichever is less.									
	Withstanding Voltage	The charge and discharge current of the capacitor must not exceed 50mA for IR and Withstanding Voltage measurement."			Resist without problem									
Moisture Resistant Load	Appearance	After applying the rated voltage for 500-512 hours in the condition of 40°C± 2°C and 90 to 95% RH, allow the parts to stabilize in normal temperature and humidity for 24 ± 2 hours, before measurement.			No defect									
	Δ C				Within ± 7.5% or ± 0.75 pF, whichever is larger									
	Q	The charge and discharge current of the capacitor must not exceed 50mA for IR measurement.			"C <sub>≥</sub> 30pF : Q <sub>≥</sub> 200 C<30pF : Q <sub>≥</sub> 100+10C/3"									
	IR				Over 500MΩ or 25MΩnμF, whichever is less.									
High-Temperature Load	Appearance				No defect									
	Δ C	After applying *twice the rated voltage in the condition of 125±3°C for 1000-1012 hours, measure the sample after 24 ± 2 hours in normal temperature and humidity. The charge and discharge current of the capacitor must not exceed 50mA for IR measurement.			Within ± 3% or ± 0.3 pF, whichever is larger									
	Q	** Applied voltages for respective products are indicated in the chart below.			C <sub>≥</sub> 30pF : Q <sub>≥</sub> 350 10pF<C<30pf : Q <sub>≥</sub> 275+5C/2 C<10pF : Q <sub>≥</sub> 200+10C									
	IR				Over 1000MΩ or 50MΩnμF, whichever is less.									

Please Ask for individual specification for the hatched range in previous chart.  
Voltage to be applied in the High Temperature Load (Applied Voltage is the multiple of the rated voltage)

Applied Voltage	Rated Voltage	Products
X 1.0	16V	CM02CΔ221
X 1.2	24V	CM02CΔR20-120

# 01005 MLCC Ultra Miniature Capacitors

## CM Series (Standard Spec. 1 & 2) Specifications and Test Methods



Test Items		Test Conditions	Specifications Standard Spec. 1	Specifications Standard Spec. 2												
Capacitance Value (C)		Measure after heat treatment	Within Tolerance	Within Tolerance												
Tan δ	Spec. 1		Refer to capacitance chart	Refer to capacitance chart												
	Capacitance	Frequency			Volt											
	C≤10 μF	1 kHz ± 10%			1.0 ± 0.2 V <sub>rms</sub>											
Spec. 2		C≤10 μF	1 kHz ± 10%	1.0 ± 0.2 V <sub>rms</sub>												
Capacitance	Frequency				Volt											
C≤10 μF	120 Hz ± 10%				0.5 ± 0.2 V <sub>rms</sub>											
		C>10 μF	120 Hz ± 10%	0.5 ± 0.2 V <sub>rms</sub>												
The charge and discharge current of the capacitor must not exceed 50mA.																
Insulation Resistance (IR)		Apply the rated voltage for 1 minute, and measure it in normal temperature and humidity. The charge and discharge current of the capacitor must not exceed 50mA.	Over 10000MΩ or 500MΩ·μF, whichever is less.	Over 50MΩ·μF												
Dielectric Resistance		Apply 2.5 times the rated voltage for 1-5 seconds. The charge and discharge current of the capacitor must not exceed 50mA.	No defect	No defect												
Appearance		Microscope	No defect	No defect												
Termination Strength		Apply a sideways force of 100g (1N) to PCB-mounted sample.	No defect	No defect												
Bending Strength		Glass epoxy PCB: Fulcrum spacing: 90mm, duration time 10 seconds.	No Significant damage with 1mm bending.	No Significant damage with 1mm bending.												
Vibration Test	Appearance	Take the initial value after heat treatment. Vibration Frequency: 10-55 (Hz) Amplitude: 1.5mm Sweeping Condition: 10_55_10 Hz/ 1 minute in X, Y and Z Directions: 2 hours each, 6 hours total, and place in normal temperature and humidity. Measure the sample after heat treatment.	No defect	No defect												
	Δ C		Within Tolerance	Within Tolerance												
	Tan δ		Within Tolerance	Within Tolerance												
Soldering Heat Resistant	Appearance	Take the initial value after heat treatment.	No defect	No defect												
	Δ C	Soak the Sample in 260°C ± 5°C solder for 10±0.5 seconds and place in normal temperature and humidity.	Within ± 7.5%	Within ± 7.5%												
	Tan δ	Measure after heat treatment. (Pre-heating conditions)	Within Tolerance	Within Tolerance												
	IR		Over 10000MΩ or 500MΩ·μF, whichever is less.	Over 50MΩ·μF												
	Withstanding Voltage	<table border="1"> <thead> <tr> <th>Order</th> <th>Temperature</th> <th>Time</th> </tr> </thead> <tbody> <tr> <td>1</td> <td>80-100°C</td> <td>2 min</td> </tr> <tr> <td>2</td> <td>150-200°C</td> <td>2 min</td> </tr> </tbody> </table> <p>The charge and discharge current of the capacitor must not exceed 50mA for IR and Withstanding Voltage measurement.</p>	Order	Temperature	Time	1	80-100°C	2 min	2	150-200°C	2 min	Resist without problem	Resist without problem			
Order	Temperature	Time														
1	80-100°C	2 min														
2	150-200°C	2 min														
Solderability		Soak Condition: <table border="1"> <thead> <tr> <th>Sn-3AG-0.5Cu</th> <th>Temperature</th> <th>Time</th> </tr> </thead> <tbody> <tr> <td></td> <td>245 ± 5°C</td> <td>3 ± 0.5 sec.</td> </tr> <tr> <th>Sn63 Solder</th> <th>Temperature</th> <th>Time</th> </tr> <tr> <td></td> <td>235 ± 5°C</td> <td>3 ± 0.5 sec.</td> </tr> </tbody> </table>	Sn-3AG-0.5Cu	Temperature	Time		245 ± 5°C	3 ± 0.5 sec.	Sn63 Solder	Temperature	Time		235 ± 5°C	3 ± 0.5 sec.	Solder Coverage : 90% min.	Solder Coverage : 90% min.
Sn-3AG-0.5Cu	Temperature	Time														
	245 ± 5°C	3 ± 0.5 sec.														
Sn63 Solder	Temperature	Time														
	235 ± 5°C	3 ± 0.5 sec.														
Temperature Cycle	Appearance	Take initial value after heat treatment.	No defect	No defect												
	Δ C	(Cycle) Room Temperature (3min.)	Within ± 7.5%	Within ± 7.5%												
	Tan δ	Lowest Operating Temperature (30 min.)	Within Tolerance	Within Tolerance												
	IR	Room Temperature (3 min.)	Over 10000MΩ or 500MΩ·μF, whichever is less.	Over 50MΩ·μF												
	Withstanding Voltage	Highest Operating Temperature (30 min.) After 5 cycles, measure after heat treatment. The charge and discharge current of the capacitor must not exceed 50mA for IR and Withstanding Voltage measurement.	Resist without problem	Resist without problem												
Moisture Resistant Load	Appearance	Take the initial value after heat treatment. After applying the rated voltage for 500-512 hours in the condition of 40°C± 2°C and 90 to 95% RH, place in normal temperature and humidity, then measure the sample after heat treatment. The charge and discharge current of the capacitor must not exceed 50mA for IR measurement.	No defect	No defect												
	Δ C		Within ± 12.5%	Within ± 12.5%												
	Tan δ		200% max. of initial value	200% max. of initial value												
	IR		Over 500MΩ or 25MΩ·μF, whichever is less.	Over 10MΩ·μF												
High-Temperature Load	Appearance	Take the initial value after heat treatment. After applying *twice the rated voltage in the highest operating temperature for 1000-1012 hours, measure the sample after heat treatment in normal temperature and humidity. The charge and discharge current of the capacitor must not exceed 50mA for IR measurement.	No defect	No defect												
	Δ C		Within ± 12.5%	Within ± 12.5%												
	Tan δ		200% max. of initial value	200% max. of initial value												
	IR	*X5R Spec 2: Apply 1.0 times when the rated voltage is 4V or less. X7R/X7R Spec 1: Apply 1.5 times when the rated Voltage is 10V or less. Applied Voltages for respective products are indicated in the chart below.	Over 1000MΩ or 50MΩ·μF, whichever is less.	Over 10MΩ·μF												
Heat Treatment		Expose sample to temperature of 140-150°C for 1 hour and leave the sample in normal temperature and humidity for 24 ± 2 hours.														

Voltage to be applied in the High Temperature Load (Applied Voltage is the multiple of the rated voltage)

Applied Voltage	Rated Voltage	Products
X1.0	10V	CM02X5R104
X1.3	6.3V	CM02X5R153-104
X1.5	16V	CM02X5R101-103, CM02X7R222

Applied Voltage	Rated Voltage	Products
X1.0	6.3V	CM02X5R224, CM02X5R474



The Important Information/Disclaimer is incorporated in the catalog where these specifications came from or available online at [www.avx.com/disclaimer/](http://www.avx.com/disclaimer/) by reference and should be reviewed in full before placing any order.

# 01005 MLCC Ultra Miniature Capacitors

## Test Conditions and Standards

Substrate for Adhesion Strength Test, Vibration Test, Soldering Heat Resistance Test, Temperature Cycle Test, Load Humidity Test, High-Temperature with Loading Test.

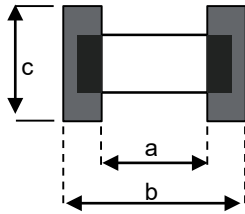

Unit: mm

Size (EIA Code)	A	B	C
02 (01005)	0.15	0.5	0.20

## SUBSTRATE FOR BENDING TEST

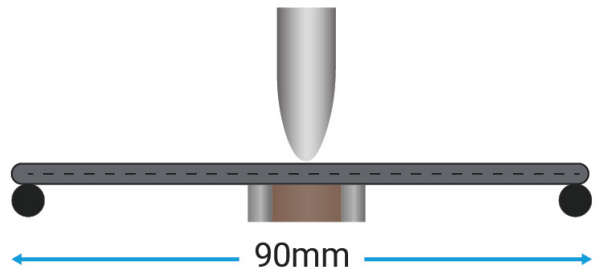
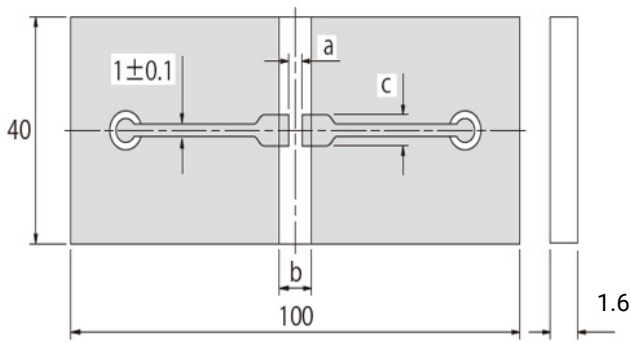

Testing Board: Glass Epoxy Board (CE4 or FR4)  
 Testing Board Thickness:  $1.6 \pm 0.2\text{mm}^*$   
 Circuit Thickness:  $0.04 \pm 0.01\text{mm}$

## STRUCTURE

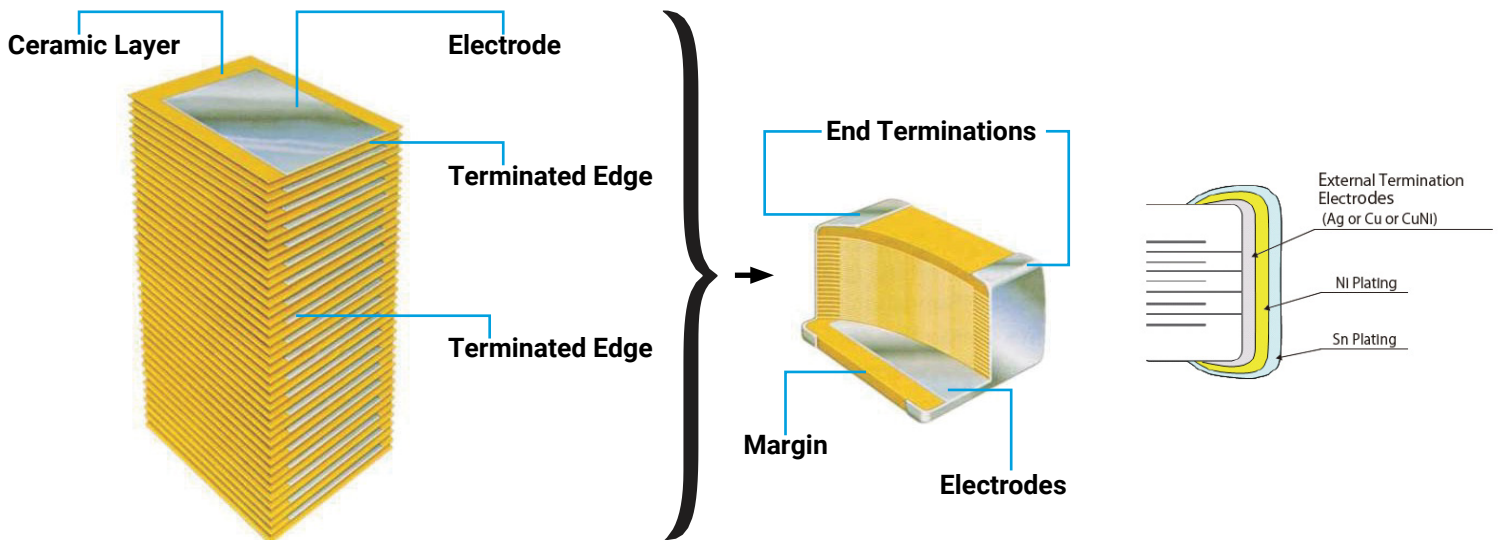

- Please contact your local AVX Sales office or distributor for specifications not covered in this catalog.
- Capacitance range is subject to change without notice
- Please contact sales representative to confirm compatibility with your application.

# 01005 MLCC Ultra Miniature Capacitors

## Packaging Options

### TAPE & REEL QUANTITIES

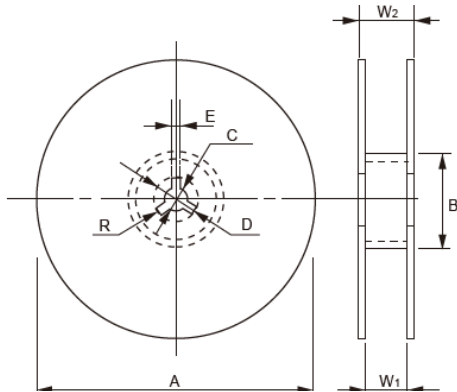

Code Reel	A	B	C	D
7- inch Reel (Code: H)	180 <sup>+0</sup> / <sub>-2.0</sub>	φ 60 min.	13 ±0.5	21 ±0.8
Code Reel	E	W <sub>1</sub>	W <sub>2</sub>	R
7- inch Reel (Code: H)	2.0 ±0.5	10.5 ±1.5	16.5 max.	1.0

### CARRIER TAPE

F = 1mm

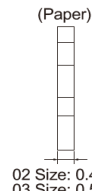
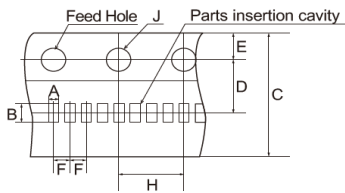

F = 2mm

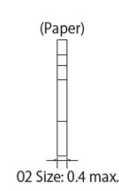
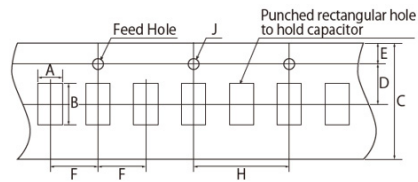

Size (EIA Code)	A	B	C	D	E	F	G	H	J	Carrier Tape	
										Width	Material
02 (01005)*	0.25 ± 0.03	0.45 ± 0.03	8.0 ± 0.3	3.5 ± 0.05	1.75 ± 0.1	2.0 ± 0.05	-	4.0 ± 0.1	1.5 ± 0.1	8mm	Paper

### DETAIL OF LEADER AND TRAILER

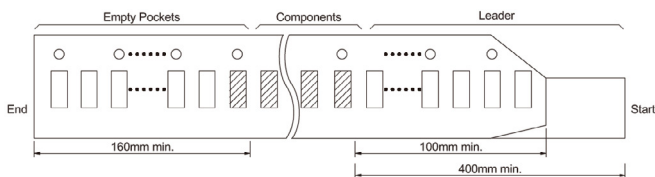

### ADHESIVE TAPE

1. The exfoliative strength when peeling off the top tape from the carrier tape by the method of the following figure shall be \*0.1 to 0.5N.
2. When the top tape is peeled off, the adhesive stays on the top tape.
3. Chip capacitors will be in a state free without being stuck on the thermal adhesive tape.2

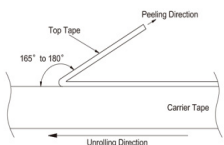

### CARRIER TAPE

1. Chip will not fall off from carrier tape or carrier tape will not be damaged by bending than within a radius of 25mm.
2. The chip are inserted continuously without any empty pocket.
3. Chip will not be mis-mounted because of too big clearance between components and cavity. Also the waste of carrier tape will not fill a nozzle hole of mounting machine.



# 01005 MLCC Ultra Miniature Capacitors

## Surface Mounting Information

### DIMENSIONS FOR RECOMMENDED TYPICAL LAND

Since the amount of solder (size of fillet) to be used has direct influence on the capacitor after mounting, the sufficient consideration is necessary. When the amounts of solder is too much, the stress that a capacitor receives becomes larger. It may become the cause of a crack in the capacitor. When the land design of printed wiring board is considered, it is necessary to set up the form and size of land pattern so that the amount of solder is suitable.

(General)

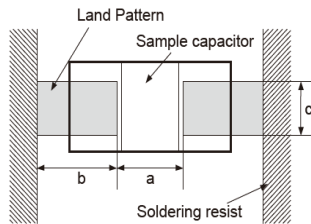

### GENERAL

"Size (EIA Code)"	Dimension		Recommended Land Dimensions		
	L	W	a	b	c
02 (01005)	0.4±0.02	0.2±0.02	0.13 to 0.20	0.12 to 0.18	0.20 to 0.23

\* Recommended land dimensions may differ depending on dimensional tolerance.

### MOUNTING DESIGN

The chip could crack if the PCB warps during processing after the chip has been soldered.

#### RECOMMENDED CHIP POSITION ON PCB TO MINIMIZE STRESS FROM PCB WARPAGE

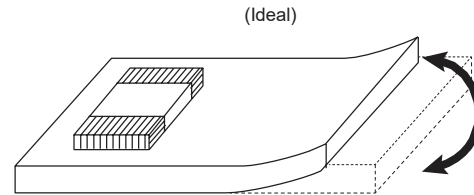
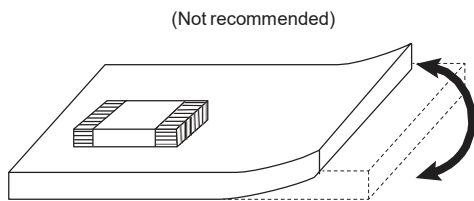

### MOUNTING

1. If the position of the vacuum nozzle is too low, a large force may be applied to the chip capacitor during mounting, resulting in cracking.
2. During mounting, set the nozzle pressure to a static load of 1 to 3 N.
3. To minimize the shock of the vacuum nozzle, provide a support pin on the back of the PCB to minimize PCB flexure.

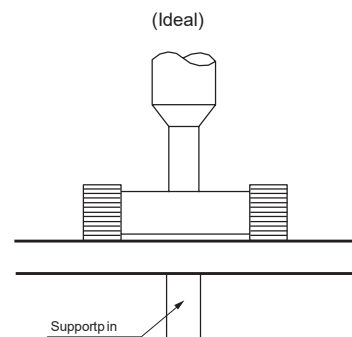
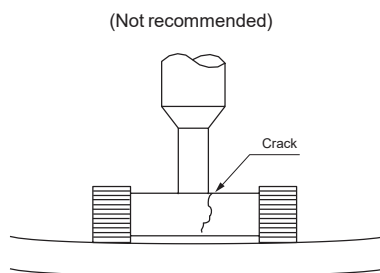

4. Bottom position of pick up nozzle should be adjusted to the top surface of a substrate when camber is corrected.

### RESIN MOLD

1. If a large amount of resin is used for molding the chip, cracks may occur due to contraction stress during curing. To avoid such cracks, use a low shrinkage resin.
2. The insulation resistance of the chip will degrade due to moisture absorption. Use a low moisture absorption resin.
3. Check carefully that the resin does not generate a decomposition gas or reaction gas during the curing process or during normal storage. Such gases may crack the chip capacitor or damage the device itself.



# 01005 MLCC Ultra Miniature Capacitors

## Surface Mounting Information

### SOLDERING METHOD

The recommended fillet height shall be 1/2 of the thickness of capacitors or 0.5mm. When mounting two or more capacitors in the common land, it is necessary to separate the land with the solder resist strike so that it may become the exclusive land of each capacitor.

### IDEAL SOLDER HEIGHT

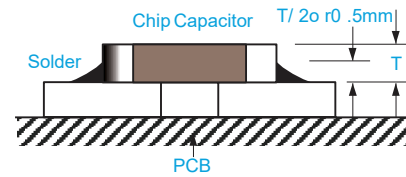

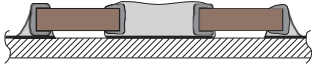
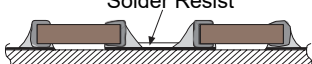
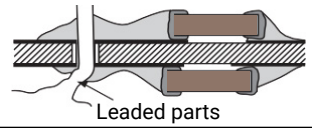
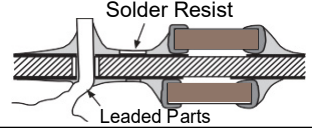
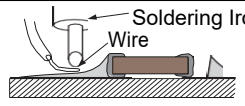
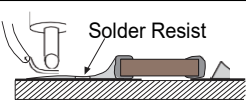
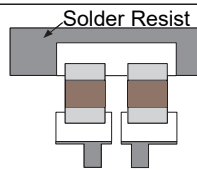
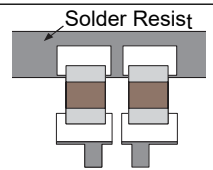
Item	Prohibited	Recommended example : Separation by solder resist
Multiple parts mount		
Mount with leaded parts		
Wire soldering after mounting		
Side by side layout		

### DESIGN OF PRINTED CIRCUIT AND SOLDERING

1. Ceramic is easily damaged by rapid heating or cooling. If some heat shock is unavoidable, preheat enough to limit the temperature difference (Delta T) to within 150 degree Celsius.
2. The product size 1.6×0.8mm to 3.2×1.6mm can be used in reflow and wave soldering, and the product size of bigger than 3.2×1.6mm, or smaller than 1.6×0.8mm can be used in reflow. Circuit shortage and smoking can be created by using capacitors which are used neglecting the above caution.
3. Please see our recommended soldering conditions.
4. In case of using Sn-Zn Solder, please contact us in advance.
5. The following condition is recommended for spot heater application.

#### RECOMMENDED SPOT HEATER CONDITION

Item	Condition
Distance	5mm min.
Angle	45°
Projection Temp.	400°C max.
Flow Rate	Set at the minimum
Nozzle Diameter	2φ to 4φ (Single hole type)
Application time	10 sec max.

How to point spot heater

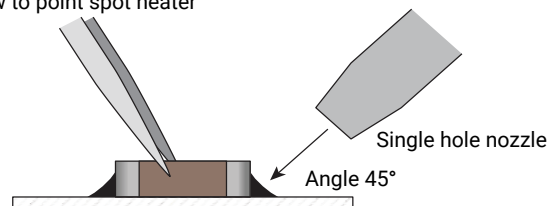

# 01005 MLCC Ultra Miniature Capacitors

## Surface Mounting Information



### RECOMMENDED TEMPERATURE PROFILE (Sn-3Ag-0.5Cu)

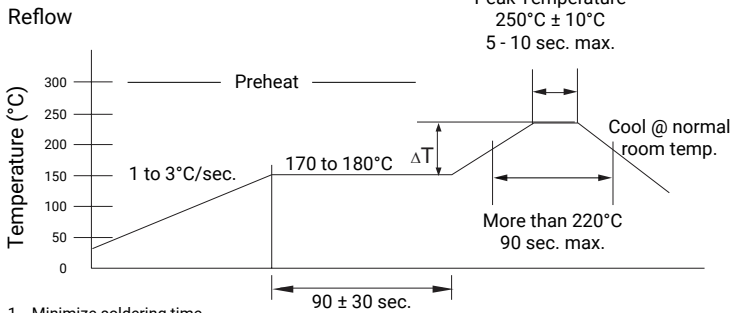

1. Minimize soldering time.
2. Ensure that allowable temperature difference does not exceed 150°C.
3. Ensure that allowable temperature difference does not exceed 130°C for 3.2x2.5mm size or larger.
4. MLCC can withstand the above reflow conditions up to 3times.
5. N<sub>2</sub>atmosphere is recommended for reflow of products of 0.4mmx0.2mm size or smaller.

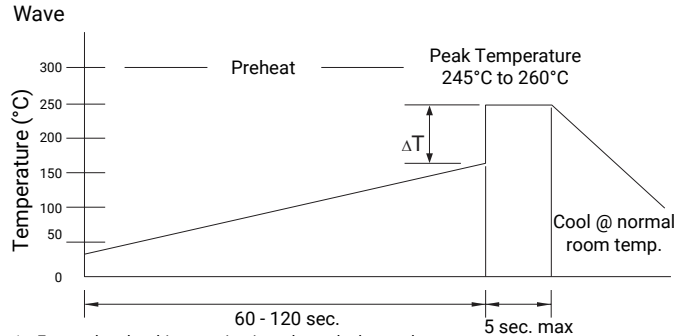

1. Ensure that the chip capacitor is preheated adequately.
2. Ensure that the temperature difference ( $\Delta T$ ) does not exceed 150°C.
3. Cool naturally after soldering. MLCC can withstand the above reflow conditions up to 3times.
4. Wave soldering is not applicable for chips with size of 3.2x2.5mm or larger of 1.0x0.5mm or smaller and capacitor arrays.

### RECOMMENDED TEMPERATURE PROFILE (63n Solder)

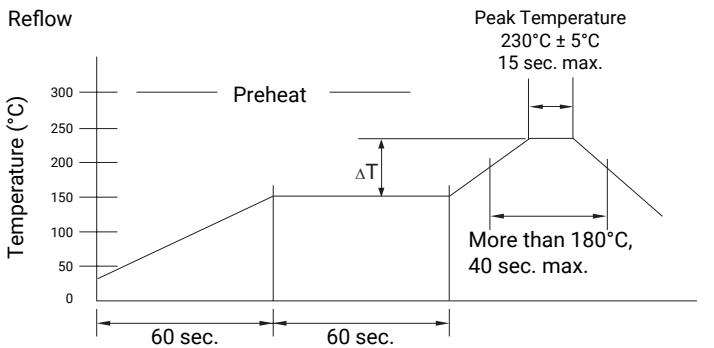

1. Minimize soldering time.
2. Ensure that the temperature difference ( $\Delta T$ ) does not exceed 150°C.
3. Ensure that the temperature difference ( $\Delta T$ ) does not exceed 130°C for 3.2x2.5mm size or larger.
4. MLCC can withstand the above reflow conditions up to 3times.

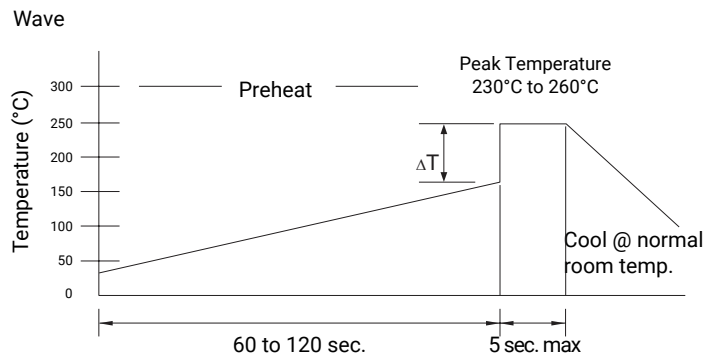

1. Ensure that the chip capacitor is preheated adequately.
2. Ensure that the temperature difference ( $\Delta T$ ) does not exceed 150°C.
3. Cool naturally after soldering.
4. Wave soldering is not applicable for chips with size of 3.2x2.5mm or larger of 1.0x0.5mm or smaller and capacitor arrays.

## Precautions

### CIRCUIT DESIGN

1. Once application and assembly environments have been checked, the capacitor may be used in conformance with the rating and performance which are provided in both the catalog and the specifications. Use exceeding that which is specified may result in inferior performance or cause a short, open, smoking, or flaming to occur, etc.
2. Please consult the manufacturer in advance when the capacitor is used in devices such as: devices which deal with human life, i.e. medical devices; which are highly public orientated; and devices which demand a high standard of liability. Accident or malfunction of devices such as medical devices, space equipment and devices having to do with atomic power could generate grave consequence with respect to human lives or, possibly, a portion of the public. Capacitors used in these devices may require high reliability design different from that of general-purpose capacitors.
3. Please use the capacitors in conformance with the operating temperature provided in both the catalog and the specifications. Be especially cautious not to exceed the maximum temperature. In the situation the maximum temperature set forth in both the catalog and specifications is exceeded, the capacitor's insulation resistance may deteriorate, power may suddenly surge and short-circuit may occur. The capacitor has a loss and may self-heat due to equivalent series resistance when alternating electric current is passed there through. As this effect becomes especially pronounced in high frequency circuits, please exercise caution. When using the capacitor in a (self-heating) circuit, please make sure the surface of the capacitor remains under the maximum temperature for usage. Also, please make certain temperature rises remain below 20°C.
4. Please keep voltage under the rated voltage which is applied to the capacitor. Also, please make certain the peak voltage remains below the rated voltage when AC voltage is super-imposed to the DC voltage. In the situation where AC or pulse voltage is employed, ensure average peak voltage does not exceed the rated voltage. Exceeding the rated voltage provided in both catalog and specifications may lead to defective withstanding voltage or, in worst case situations, may cause the capacitor to smoke or flame.
5. When the capacitor is to be employed in a circuit in which there is continuous application of a high frequency voltage or a steep pulse voltage, even though it is within the rated voltage, please inquire to the manufacturer. In the situation the capacitor is to be employed using a high frequency AC voltage or an extremely fast rising pulse voltage, even though it is within the rated voltage, it is possible capacitor reliability will deteriorate.
6. It is a common phenomenon of high-dielectric products to have a deteriorated amount of static electricity due to the application of DC voltage. Due caution is necessary as the degree of deterioration varies depending on the quality of capacitor materials, capacity, as well as the load voltage at the time of operation.
7. Do not use the capacitor in an environment where it might easily exceed the respective provisions concerning shock and vibration specified in the catalog and specifications. In addition, it is a common piezo phenomenon of high dielectric products to have some voltage due to vibration or to have noise due to voltage change. Please contact sales in such case.
8. If the electrostatic capacity value of the delivered capacitor is within the specified tolerance, please consider this when designing the respective product in order that the assembled product function appropriately.
9. Please contact us upon using conductive adhesives.

### STORAGE

1. If the component is stored in minimal packaging (a heat-sealed or zippered plastic bag), the bag should be kept closed. Once the bag has been opened, reseal it or store it in a desiccator.
2. Keep storage place temperature +5 to +40 °C, humidity 20 to 70% RH. See JIS C 6 0721-3-1, class 1K2 for other climatic conditions.
3. The storage atmosphere must be free of corrosive gas such as sulfur dioxide and chlorine. Also, avoid exposing the product to saline moisture. If the product is exposed to such atmospheres, the terminals will oxidize and solderability will be effected.
4. Precautions 1) to 3) apply to chip capacitors packaged in carrier tapes.
5. The solderability is assured for 6 months from our shipping date if the above storage precautions are followed.

# 01005 MLCC Ultra Miniature Capacitors

## Part Number List



General CM02 Series Size (JIS Code): 01005(0402)# Packaging Code (Packaging quantity): H(20,000pcs.)

Dielectric code CA	Capacitance	□:Tolerance	Voltage [V]	Part Number	Q	Dimension			# Packaging Code (quantity)		
						L [mm]	W [mm]	T [mm]			
CG	1.0pF	B: ± 0.1pF C: ± 0.25pF	25	CM02C Δ 1R0 □ 25A#	420	0.4± 0.02	0.2± 0.02	0.2± 0.02	H		
	1.5pF			CM02C Δ 1R5 □ 25A#	430	0.4± 0.02	0.2± 0.02	0.2± 0.02	H		
	2.0pF			CM02C Δ 2R0 □ 25A#	440	0.4± 0.02	0.2± 0.02	0.2± 0.02	H		
	3.0pF			CM02C Δ 3R0 □ 25A#	460	0.4± 0.02	0.2± 0.02	0.2± 0.02	H		
	4.0pF			CM02C Δ 4R0 □ 25A#	480	0.4± 0.02	0.2± 0.02	0.2± 0.02	H		
	5.0pF			CM02C Δ 5R0 □ 25A#	500	0.4± 0.02	0.2± 0.02	0.2± 0.02	H		
	6.0pF	C: ± 0.25pF	25	CM02C Δ 6R0 □ 25A#	520	0.4± 0.02	0.2± 0.02	0.2± 0.02	H		
	7.0pF			CM02C Δ 7R0 □ 25A#	540	0.4± 0.02	0.2± 0.02	0.2± 0.02	H		
	8.0pF			CM02C Δ 8R0 □ 25A#	560	0.4± 0.02	0.2± 0.02	0.2± 0.02	H		
	9.0pF			CM02C Δ 9R0 □ 25A#	580	0.4± 0.02	0.2± 0.02	0.2± 0.02	H		
	10pF			CM02C Δ 100 □ 25A#	600	0.4± 0.02	0.2± 0.02	0.2± 0.02	H		
	12pF			J: ± 5%	25	CM02C Δ 120 □ 25A#	640	0.4± 0.02	0.2± 0.02	0.2± 0.02	H
	15pF	CM02C Δ 150 □ 25A#	700			0.4± 0.02	0.2± 0.02	0.2± 0.02	H		
	18pF	CM02C Δ 180 □ 25A#	760			0.4± 0.02	0.2± 0.02	0.2± 0.02	H		
	22pF	CM02C Δ 220 □ 25A#	840			0.4± 0.02	0.2± 0.02	0.2± 0.02	H		
	27pF	J: ± 5%	16			CM02C Δ 270 □ 16A#	940	0.4± 0.02	0.2± 0.02	0.2± 0.02	H
	33pF					CM02C Δ 330 □ 16A#	1000	0.4± 0.02	0.2± 0.02	0.2± 0.02	H
	39pF					CM02C Δ 390 □ 16A#	1000	0.4± 0.02	0.2± 0.02	0.2± 0.02	H
	47pF					CM02C Δ 470 □ 16A#	1000	0.4± 0.02	0.2± 0.02	0.2± 0.02	H
	56pF					CM02C Δ 560 □ 16A#	1000	0.4± 0.02	0.2± 0.02	0.2± 0.02	H
	68pF					CM02C Δ 680 □ 16A#	1000	0.4± 0.02	0.2± 0.02	0.2± 0.02	H
	82pF			CM02C Δ 820 □ 16A#	1000	0.4± 0.02	0.2± 0.02	0.2± 0.02	H		
100pF	CM02C Δ 101 □ 16A#			1000	0.4± 0.02	0.2± 0.02	0.2± 0.02	H			
220pF	CM02C Δ 221 □ 16A#			1000	0.4± 0.02	0.2± 0.02	0.2± 0.02	H			
100pF	K: ± 10% M: ± 20%			16	CM02X5R101 □ 16A#	12.5	0.4 ± 0.02	0.2 ± 0.02	0.2 ± 0.02	H	
150pF		CM02X5R151 □ 16A#	12.5		0.4 ± 0.02	0.2 ± 0.02	0.2 ± 0.02	H			
220pF		CM02X5R221 □ 16A#	12.5		0.4 ± 0.02	0.2 ± 0.02	0.2 ± 0.02	H			
330pF		CM02X5R331 □ 16A#	12.5		0.4 ± 0.02	0.2 ± 0.02	0.2 ± 0.02	H			
470pF		CM02X5R471 □ 16A#	12.5		0.4 ± 0.02	0.2 ± 0.02	0.2 ± 0.02	H			
680pF		CM02X5R681 □ 16A#	12.5		0.4 ± 0.02	0.2 ± 0.02	0.2 ± 0.02	H			
1000pF		CM02X5R102 □ 16A#	12.5		0.4 ± 0.02	0.2 ± 0.02	0.2 ± 0.02	H			
1500pF		CM02X5R152 □ 16A#	12.5		0.4 ± 0.02	0.2 ± 0.02	0.2 ± 0.02	H			
2200pF		CM02X5R222 □ 16A#	12.5		0.4 ± 0.02	0.2 ± 0.02	0.2 ± 0.02	H			
4700pF		CM02X5R472 □ 16A#	12.5		0.4 ± 0.02	0.2 ± 0.02	0.2 ± 0.02	H			
6800pF		CM02X5R682 □ 16A#	12.5		0.4 ± 0.02	0.2 ± 0.02	0.2 ± 0.02	H			
10000pF		CM02X5R103 □ 16A#	12.5		0.4 ± 0.02	0.2 ± 0.02	0.2 ± 0.02	H			
15000pF		CM02X5R153 □ 06A#	12.5		0.4 ± 0.02	0.2 ± 0.02	0.2 ± 0.02	H			
22000pF		CM02X5R223 □ 06A#	12.5		0.4 ± 0.02	0.2 ± 0.02	0.2 ± 0.02	H			
33000pF		CM02X5R333 □ 06A#	12.5		0.4 ± 0.02	0.2 ± 0.02	0.2 ± 0.02	H			
47000pF		CM02X5R473 □ 06A#	12.5		0.4 ± 0.02	0.2 ± 0.02	0.2 ± 0.02	H			
0.10μF		M: ± 20%	10		CM02X5R104 □ 10A#	12.5	0.4 ± 0.02	0.2 ± 0.02	0.2 ± 0.02	H	
0.10μF		K: ± 10%	6.3		CM02X5R104 □ 06A#	12.5	0.4 ± 0.02	0.2 ± 0.02	0.2 ± 0.02	H	
	M: ± 20%										
0.22μF	M: ± 20%	6.3	CM02X5R224M06A#	12.5	0.4 ± 0.02	0.2 ± 0.02	0.2 ± 0.02	H			
			CM02X5R474M06A#	12.5	0.4 ± 0.02	0.2 ± 0.02	0.2 ± 0.02	H			
X7R	2200μF	K: ± 10%	16	CM02X7R222 □ 16A#	12.5	0.4 ± 0.02	0.2 ± 0.02	0.2 ± 0.02	H		
		M: ± 20%									

# 01005 MLCC Ultra Miniature Capacitors

## Part Number List



General CM02 Series Size (JIS Code): 01005(0402)# Packaging Code (Packaging quantity): H(20,000pcs.)

Dielectric code CΔ	Capacitance	□:Tolerance	Voltage [V]	Part Number	Dimension			# Packaging Code (quantity)	
					L [mm]	W [mm]	T [mm]		
CG	R50	C: ± 0.25pF	25	CU02C Δ R50 □ 25AH	0.4± 0.02	0.2± 0.02	0.2± 0.02	H	
	1.0pF			CU02C Δ 1R0 □ 25AH	0.4± 0.02	0.2± 0.02	0.2± 0.02	H	
	1.5pF			CU02C Δ 1R5 □ 25AH	0.4± 0.02	0.2± 0.02	0.2± 0.02	H	
	2.0pF			CU02C Δ 2R0 □ 25AH	0.4± 0.02	0.2± 0.02	0.2± 0.02	H	
	3.0pF			CU02C Δ 3R0 □ 25AH	0.4± 0.02	0.2± 0.02	0.2± 0.02	H	
	4.0pF			CU02C Δ 4R0 □ 25AH	0.4± 0.02	0.2± 0.02	0.2± 0.02	H	
	5.0pF			CU02C Δ 5R0 □ 25AH	0.4± 0.02	0.2± 0.02	0.2± 0.02	H	
	6.0pF			CU02C Δ 6R0 □ 25AH	0.4± 0.02	0.2± 0.02	0.2± 0.02	H	
	7.0pF			CU02C Δ 7R0 □ 25AH	0.4± 0.02	0.2± 0.02	0.2± 0.02	H	
	8.0pF			CU02C Δ 8R0 □ 25AH	0.4± 0.02	0.2± 0.02	0.2± 0.02	H	
	9.0pF	CU02C Δ 9R0 □ 25AH	0.4± 0.02	0.2± 0.02	0.2± 0.02	H			
	10pF	J: ± 5%	25	CU02C Δ 100 □ 25AH	0.4± 0.02	0.2± 0.02	0.2± 0.02	H	
	12pF			CU02C Δ 120 □ 25AH	0.4± 0.02	0.2± 0.02	0.2± 0.02	H	
	R20	"B: ± 0.1pF C: ± 0.25pF "	16	CU02C Δ R20 □ 16AH	0.4± 0.02	0.2± 0.02	0.2± 0.02	H	
	R50			CU02C Δ R50 □ 16AH	0.4± 0.02	0.2± 0.02	0.2± 0.02	H	
	1R0			CU02C Δ 1R0 □ 16AH	0.4± 0.02	0.2± 0.02	0.2± 0.02	H	
	1R5			CU02C Δ 1R5 □ 16AH	0.4± 0.02	0.2± 0.02	0.2± 0.02	H	
	2R0			CU02C Δ 2R0 □ 16AH	0.4± 0.02	0.2± 0.02	0.2± 0.02	H	
	3R0			CU02C Δ 3R0 □ 16AH	0.4± 0.02	0.2± 0.02	0.2± 0.02	H	
	4R0			CU02C Δ 4R0 □ 16AH	0.4± 0.02	0.2± 0.02	0.2± 0.02	H	
5R0	CU02C Δ 5R0 □ 16AH			0.4± 0.02	0.2± 0.02	0.2± 0.02	H		
6R0	C: ± 0.25pF	16	CU02C Δ 6R0 □ 16AH	0.4± 0.02	0.2± 0.02	0.2± 0.02	H		
7R0			CU02C Δ 7R0 □ 16AH	0.4± 0.02	0.2± 0.02	0.2± 0.02	H		
8R0			CU02C Δ 8R0 □ 16AH	0.4± 0.02	0.2± 0.02	0.2± 0.02	H		
9R0			CU02C Δ 9R0 □ 16AH	0.4± 0.02	0.2± 0.02	0.2± 0.02	H		
10pF			J: ± 5%	16	CU02C Δ 100 □ 16AH	0.4± 0.02	0.2± 0.02	0.2± 0.02	H
12pF					CU02C Δ 120 □ 16AH	0.4± 0.02	0.2± 0.02	0.2± 0.02	H
15pF	CU02C Δ 150 □ 16AH	0.4± 0.02			0.2± 0.02	0.2± 0.02	H		
18pF	CU02C Δ 180 □ 16AH	0.4± 0.02			0.2± 0.02	0.2± 0.02	H		
22pF	CU02C Δ 220 □ 16AH	0.4± 0.02			0.2± 0.02	0.2± 0.02	H		